

Autonics

Single-Phase, Integrated Heatsink Type SSR [Left-Right Terminal] SRHL1 SERIES

INSTRUCTION MANUAL



Thank you for choosing our Autonics product. Please read the following safety considerations before use.

■ Safety Considerations

※Please observe all safety considerations for safe and proper product operation to avoid hazards.
 ※⚠ symbol represents caution due to special circumstances in which hazards may occur.

⚠ Warning Failure to follow these instructions may result in serious injury or death.
⚠ Caution Failure to follow these instructions may result in personal injury or product damage.

⚠ Warning

- Fail-safe device must be installed when using the unit with machinery that may cause serious injury or substantial economic loss.** (e.g. nuclear power control, medical equipment, ships, vehicles, railways, aircraft, combustion apparatus, safety equipment, crime/disaster prevention devices, etc.)
Failure to follow this instruction may result in fire, personal injury, or economic loss.
- Install on a device panel or DIN rail to use.**
Failure to follow this instruction may result in electric shock or fire.
- Do not connect, repair, or inspect the unit while connected to a power source.**
Failure to follow this instruction may result in electric shock or fire.
- Check 'Connections' before wiring.**
Failure to follow this instruction may result in fire.
- Do not disassemble or modify the unit.**
Failure to follow this instruction may result in electric shock or fire.

⚠ Caution

- Use the unit within the rated specifications.**
Failure to follow this instruction may result in fire or product damage.
- Use dry cloth to clean the unit, and do not use water or organic solvent.**
Failure to follow this instruction may result in electric shock or fire.
- Do not use the unit in the place where flammable/explosive/corrosive gas, humidity, direct sunlight, radiant heat, vibration, impact, or salinity may be present.**
Failure to follow this instruction may result in fire or explosion.
- Keep metal chip, dust, and wire residue from flowing into the unit.**
Failure to follow this instruction may result in fire or product damage.
- Since leakage current still flows right after turning off the power or in the output OFF status, do not touch the load terminal.**
Failure to follow this instruction may result in electric shock.

■ Dimensions

• Rated load current 10A/15A/20A/25A

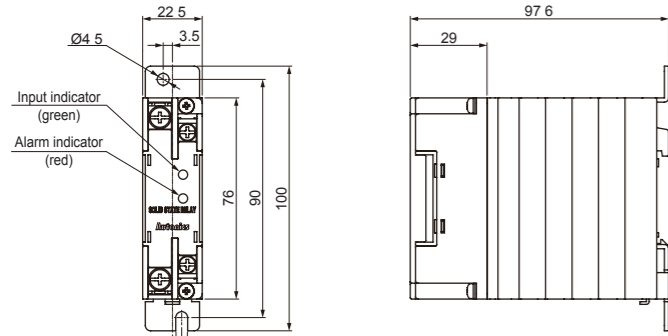

• Rated load current 40A

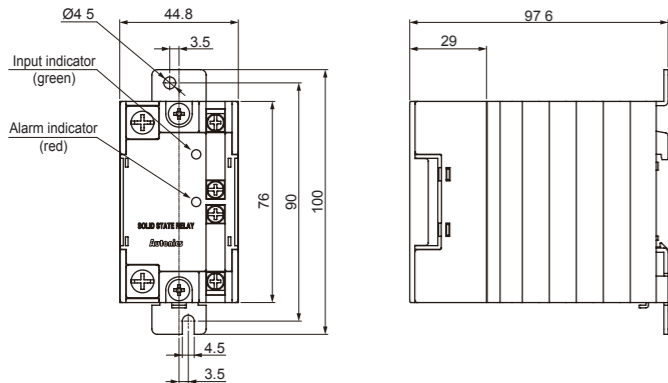

※The above specifications are subject to change and some models may be discontinued without notice.
 ※Be sure to follow cautions written in the instruction manual and the technical descriptions (catalog, homepage).

■ Model

Model	Rated input voltage	Rated load current	Rated load voltage	Function	Alarm (overheat prevention)
SRHL1-1210	10-30VDC	10A	24-240VAC	Zero cross turn-on	Alarm indicator
SRHL1-4210	90-240VAC				
SRHL1-1215	10-30VDC				
SRHL1-1215	10-30VDC	15A	24-240VAC	Zero cross turn-on	Alarm indicator
SRHL1-4215	90-240VAC				
SRHL1-1220	10-30VDC				
SRHL1-1220	10-30VDC	20A	24-240VAC	Zero cross turn-on	Alarm indicator
SRHL1-4220	90-240VAC				
SRHL1-1225	10-30VDC				
SRHL1-1225	10-30VDC	25A	24-240VAC	Zero cross turn-on	Alarm indicator
SRHL1-4225	90-240VAC				
SRHL1-1240	10-30VDC				
SRHL1-1240	10-30VDC	40A	48-480VAC	Zero cross turn-on	Alarm indicator + Alarm output
SRHL1-4240	90-240VAC				
SRHL1-1410	10-30VDC				
SRHL1-1410R	10-30VDC	10A	48-480VAC	Random turn-on	Alarm indicator
SRHL1-4410	90-240VAC				
SRHL1-1415	10-30VDC				
SRHL1-1415R	10-30VDC	15A	48-480VAC	Random turn-on	Alarm indicator
SRHL1-4415	90-240VAC				
SRHL1-1420	10-30VDC				
SRHL1-1420R	10-30VDC	20A	48-480VAC	Random turn-on	Alarm indicator
SRHL1-4420	90-240VAC				
SRHL1-1425	10-30VDC				
SRHL1-1425R	10-30VDC	25A	48-480VAC	Random turn-on	Alarm indicator
SRHL1-4425	90-240VAC				
SRHL1-1440	10-30VDC				
SRHL1-1440R	10-30VDC	40A	48-480VAC	Random turn-on	Alarm indicator + Alarm output
SRHL1-4440	90-240VAC				
SRHL1-1440R	10-30VDC				
SRHL1-4440	90-240VAC			Zero cross turn-on	

■ Connections

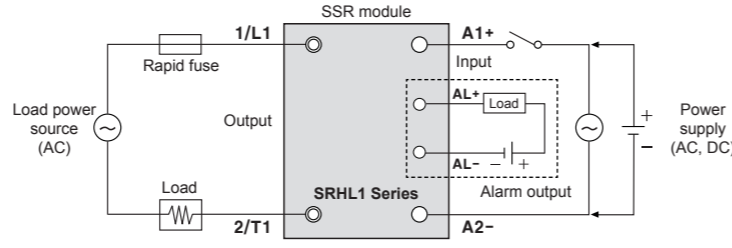

※Alarm output terminals (AL) are only for the rated load current 40A model (SRHL1-□□40□).
 ※Use terminals of size specified below.

Terminal type	Input, alarm output	Output
Rated load current	10A, 15A, 20A, 25A, 40A	10A, 15A, 20A, 25A, 40A
	a Min. 3.5mm	Min. 4.0mm
	b Max. 7.0mm	Max. 9.0mm
		Min. 5.0mm
		Max. 12.0mm

○ Panel cut-out

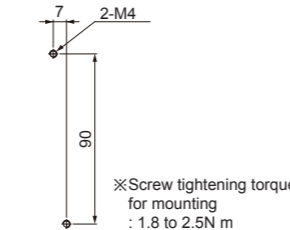

○ Spacing

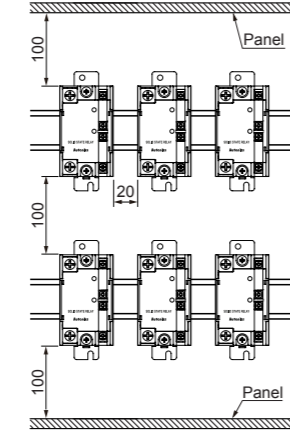

※When installing multiple SSRs, please keep space between SSRs for heat radiation. When installing SSRs horizontally (input part and output part on the same height), please supply less than 50% of the rated load current.

○ DIN rail mounting

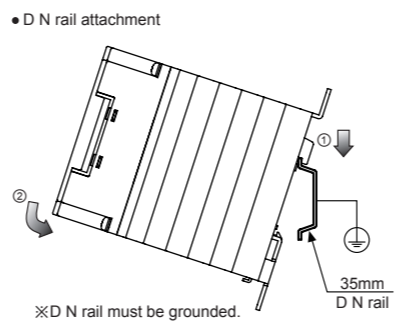

○ D N rail detachment

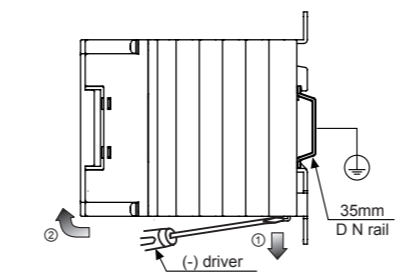

⚠ High Temperature Caution

While supplying power to the load or right after turning off the power of the load, do not touch the body and heat sink. Failure to follow this instruction may result in a burn due to the high temperature.

■ Specifications

○ Input

Rated input voltage range	10-30VDC≒	90-240VACrms~ (50/60Hz)
Allowable input voltage range	9-32VDC≒	85-264VACrms~ (50/60Hz)
Max. input current	15mA	22mA
Pick-up voltage	Min. 9VDC≒	Min. 85VACrms~
Drop-out voltage	Max. 1VDC≒	Max. 10VACrms~
Turn-ON time	Zero cross turn-on	Max. 0.5 cycle of load source + 1ms
	Random turn-on	Max. 2 cycle of load source + 1ms
Turn-off time	Zero cross turn-on	Max. 1ms
	Random turn-on	Max. 0.5 cycle of load source + 1ms

○ Output

Rated load voltage range	24-240VACrms~ (50/60Hz)				
Allowable load voltage range	24-264VACrms~ (50/60Hz)				
Rated load current (AC-51) ^{※1}	10Arms	15Arms	20Arms	25Arms	40Arms
	Resistive load				
Min. load current	0.15Arms	0.15Arms	0.2Arms	0.2Arms	0.5Arms
Max. 1 cycle surge current (60Hz)	160A	160A	250A	250A	400A
Max. non-repetitive surge current (I _t , t=8.3ms)	130A ² s	130A ² s	300A ² s	300A ² s	910A ² s
Peak voltage (non-repetitive)	600V				
Leakage current (Ta=25°C)	Max. 10mA (240VAC~/60Hz)				
Output on voltage drop [Vp] (max. load current)	Max. 1.6V				
Static off state dv/dt	500V/μs				
Rated load voltage range	48-480VACrms~ (50/60Hz)				
Allowable load voltage range	48-528VACrms~ (50/60Hz)				
Rated load current (AC-51) ^{※1}	10Arms	15Arms	20Arms	25Arms	40Arms
	Resistive load				
Min. load current	0.5Arms	0.5Arms	0.5Arms	0.5Arms	0.5Arms
Max. 1 cycle surge current (60Hz)	300A	300A	500A	500A	500A
Max. non-repetitive surge current (I _t , t=8.3ms)	350A ² s	350A ² s	1000A ² s	1000A ² s	1000A ² s
Peak voltage (non-repetitive)	1200V (Zero cross turn-on), 1000V (Random turn-on)				
Leakage current (Ta=25°C)	Max. 10mA (480VAC~/60Hz)				
Output on voltage drop [Vp] (max. load current)	Max. 1.6V				
Static off state dv/dt	500V/μs				

※1: AC-51 is utilization category at IEC60947-4-3.

○ Alarm output (Overheat prevention)

Rated input voltage range	10-30VDC≒	90-240VACrms~ (50/60Hz)
Load voltage	Max. 30VDC≒	Max. 30VDC≒
Load current	Max. 50mA	Max. 50mA
Turn-off time	Max. 50ms	Max. 100ms

※Overheat prevention function: When SSR internal temperature is overheated, the load output is cut off to prevent internal device damage. The alarm indicator turns ON and alarm output turns ON.
 ※Alarm output is only for the rated load current 40A model (SRHL1-□□40□).
 In case of the rated load current 10A/15A/20A/25A models (SRHL1-□□10□□15□□20□□25□), the alarm indicator turns ON, regardless of alarm output.
 ※To clear alarm, cut OFF the input signal during over alarm output return time at the rated ambient temperature.

○ General specifications

Dielectric strength (Vrms)	• Input-output: 2500VAC 50/60Hz for 1 min • Input/output-case: 4000VAC 50/60Hz for 1 min
Insulation resistance	Over 100MΩ (at 500VDC megger) (input-output, input/output-case)
Indicator	Input indicator: green LED, alarm indicator: red LED
Vibration	Mechanical 0.75mm amplitude at frequency of 10 to 55Hz (for 1 min) in each X, Y, Z direction for 1 hour
	Malfuction 0.5mm amplitude at frequency of 10 to 55Hz (for 1 min) in each X, Y, Z direction for 10 min
Shock	Mechanical 300m/s ² (approx. 30G) in each X, Y, Z direction for 3 times
	Malfuction 100m/s ² (approx. 30G) in each X, Y, Z direction for 3 times
Environment	Ambient temperature -30 to 70°C, storage: -30 to 100°C (The rated load current capacity is different depending on ambient temperature. Refer to ■ SSR Derating Curve.)
	Ambient humidity 45 to 85%RH, storage: 45 to 85%RH
Input terminal connection, alarm output terminal connection	Min. 1×0.5mm ² (1×AWG20), max. 1×4mm ² (1×AWG12) or 2×1.5mm ² (2×AWG16)
Output terminal connection	• Rated load current 10A/15A/20A/25A: Min. 1×0.75mm ² (1×AWG18), max. 1×6mm ² (1×AWG10) or 2×2.5mm ² (2×AWG14) • Rated load current 40A: Min. 1×1.5mm ² (1×AWG16), max. 1×16mm ² (1×AWG6) or 2×6mm ² (2×AWG10) ※Use wires compliant with load current capacity to connect to the terminal.
Input terminal fixed torque	0.75 to 0.95N·m
Output terminal fixed torque	• Rated load current 10A/15A/20A/25A: 1.0 to 1.35N·m • Rated load current 40A: 1.6 to 2.2N·m
Approval	CE, UL, etc.
Weight ^{※1}	• Rated load current 10A/15A/20A/25A: Approx. 270g (approx. 192g) • Rated load current 40A: Approx. 468g (approx. 372g)

※1: The weight includes packaging. The weight in parenthesis is for unit only.
 ※Environment resistance is rated at no freezing or condensation.
 ※For wiring the terminal, round terminal must be used.

■ SSR Derating Curve

○ SRHL1-1210/1410/1410R/4210/4410

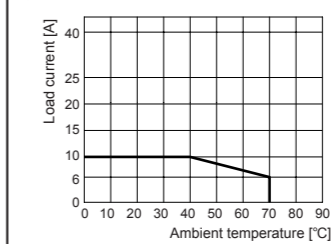

○ SRHL1-1215/1415/1415R/4215/4415

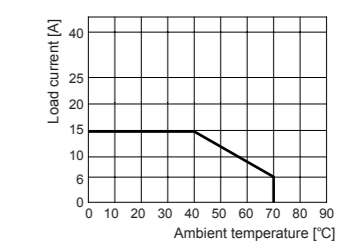

○ SRHL1-1220/1420/1420R/4220/4420

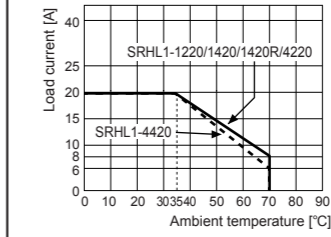

○ SRHL1-1225/1425/1425R/4225/4425

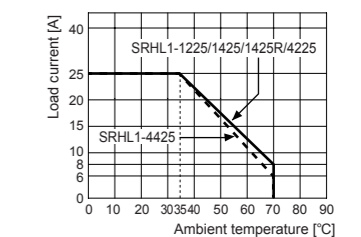

○ SRHL1-1240/1440/1440R/4240/4440

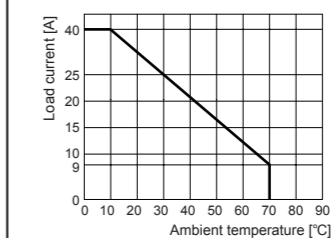

⚠ Since effectiveness of the heat radiation is decreased when multiple SSRs are installed closely, please supply less than 50% of the rated load current.
 ※Above SSR derating curves obtained approval from the UL certification authority.

■ Cautions during Use

- Follow instructions in 'Cautions during Use'. Otherwise, it may cause unexpected accidents.
- 10-30VDC signal input should be insulated and limited voltage/current or Class 2, SELV power supply device.
- Install the unit in the well ventilated place.
- Ground to the heat sink, panel, or DIN rail.
- Failure to follow this instruction may result in electric shock.
- While supplying power to the load or right after turning off the power of the load, do not touch the body and heat sink.
- Failure to follow this instruction may result in a burn due to the high temperature.
- In order to protect the product from the short-circuit current of the load, use rapid fuse of which I_tt is under the 1/2 of SSR I_tt. When short-circuited, replace the fuse to those of same specification with the used rapid fuse.
- Install dummy resistance in parallel with the load, to keep the sum of current flowing in the load and dummy resistance being over SSR minimum load current.
- When using random turn-on model for phase control, install noise filter between the load and the power of the load.
- Do not use near the equipment which generates strong magnetic force or high frequency noise.
- This unit may be used in the following environments.
 - Indoors (in the environment condition rated in 'Specifications')
 - Altitude max. 2,000m
 - Pollution degree 2
 - Installation category III

■ Major Products

- Photoelectric Sensors
- Fiber Optic Sensors
- Door Sensors
- Door Side Sensors
- Area Sensors
- Proximity Sensors
- Pressure Sensors
- Rotary Encoders
- Connectors/Sockets
- Switching Mode Power Supplies
- Control Switches/Lamps/Buzzers
- I/O Terminal Blocks & Cables
- Stepper Motors/Drivers/Motion Controllers
- Graphic/Logic Panels
- Field Network Devices
- Laser Marking System(Fiber, Co₂, Nd:YAG)
- Laser Welding/Cutting System
- Temperature Controllers
- Temperature/Humidity Transducers
- SSRs/Power Controllers
- Counters
- Timers
- Panel Meters
- Tachometers/Pulse(Rate) Meters
- Display Units
- Sensor Controllers